

# Custom Wine Cellar Instruction Manual

## TABLE OF CONTENTS

<b>1. INITIAL LAYOUT AND TIPS ON INSTALLATION.....</b>	<b>1</b>
<b>2. BUILDING INDIVIDUAL WINE RACKS.....</b>	<b>2</b>
2.1 LADDER RACKS.....	2
2.2 TABLE HEIGHT RACKS.....	5
2.3 DISPLAY RACKS.....	5
2.4 CASCADE RACKS.....	5
2.5 SEGMENTED CURVED CORNER RACKS.....	7
2.6 HIGH REVEAL.....	10
2.7 DIAMOND BINS.....	12
2.8 CURVED CORNER RACKS.....	14
2.9 RECTANGULAR BINS.....	16
2.10 VERTICAL DISPLAYS.....	18
2.11 ARCHTOPS.....	19
2.12 QUARTER ROUND SHELVES.....	21
2.13 WOOD CASE WITH PULL OUT SHELVES.....	23
2.14 STEMWARE RACKS.....	25
<b>3. FINISH WORK.....</b>	<b>25</b>
3.1 FINAL ASSEMBLY.....	25
3.2 CORNERS.....	26
3.3 CROWN AND BASE MOLDING.....	26
3.4 FINISHING TOUCHES.....	26

# 1. Initial Layout and Tips on Installation

To get started, review and familiarize yourself with the cellar floor plan comparing the floor plan dimensions with the actual dimensions of the cellar space. Each individual rack section has been assigned a letter on the floor plan and your racking has been labeled with the corresponding letter. If possible, lay out the contents of each rack section in an open area where the contents can be viewed, insuring all parts are enclosed.

As a general rule it is best to start by assembling the racks that are on the wall opposite the entry door and work around the room towards the door. After all racks are assembled and in position they will need to be shimmed to plumb and level. They should be attached to each other using 1-1/4" pneumatic nails and fastened securely to the walls at stud locations using wood screws. This needs to be accomplished before any final finish work and moldings are applied. There is more detailed instruction on this in the Finishing Touches section.

The individual racks have been shipped to you in ladder form. Ladders consist of two uprights with slats running perpendicular to them. Most of our custom racking is designed to run from the floor to the ceiling, for this reason it is necessary to assemble the racks vertically rather than on the floor. **Assembling the racks on the floor will run the risk of them hitting the ceiling before they are upright and is not recommended.**

## **Tools Recommended for Installation:**

1. Pneumatic nail gun with 1 1/2" and 1 1/4" galvanized finish nails
2. Soft faced rubber or plastic hammer or mallet
3. Electric drill or cordless screw gun with 1 1/2" long #8 wood screws
4. Drill bits and countersinks
5. Carpenters wood glue
6. 4 foot level
7. Chalk line
8. Chop saw
9. Coping saw
10. Framing square
11. Tape measure

You are now ready to begin assembly. Section 2 will lead you through the assembly of all the racking components you may have purchased, beginning with ladder assemblies. Ladder assemblies are usually the basic building blocks of our wine rack system and can come in many different styles and sizes; you should therefore note the differences between those in your design before beginning assembly. The first part of Section 2 will lead you through the basics of building all ladder type racks, with more explanation given in later sections, on each of the styles.

## 2. Building Individual Wine Racks



### 2.1 *Ladder Racks*

Individual racks consist of vertical ladders and horizontal spacer bars; ladders can have slats on one side of the uprights (single ladder) or on both sides (double ladders). Singles can be a left or right side and all have a distinctive top and bottom as well as back and front. The ladder bottoms have slats starting 2 1/2" in from the ends. The rack front can be distinguished by the angled slats it has in most locations, except a few that have flat faces and are set back from the uprights by 3/4". The back slats all have flat faces and are flush with the upright (except the few locations set back 3/4"). See **figure 1** on page 3.

The set back slat locations are made to accept the horizontal spacer bars; spacer bars have a series of square cut outs known as dadoes, that fit over the uprights of the ladders (see **figure 2** on page 3). Each lettered rack section will have ladders and a set of matching spacer bars with a number of dadoes to match the number of ladders.

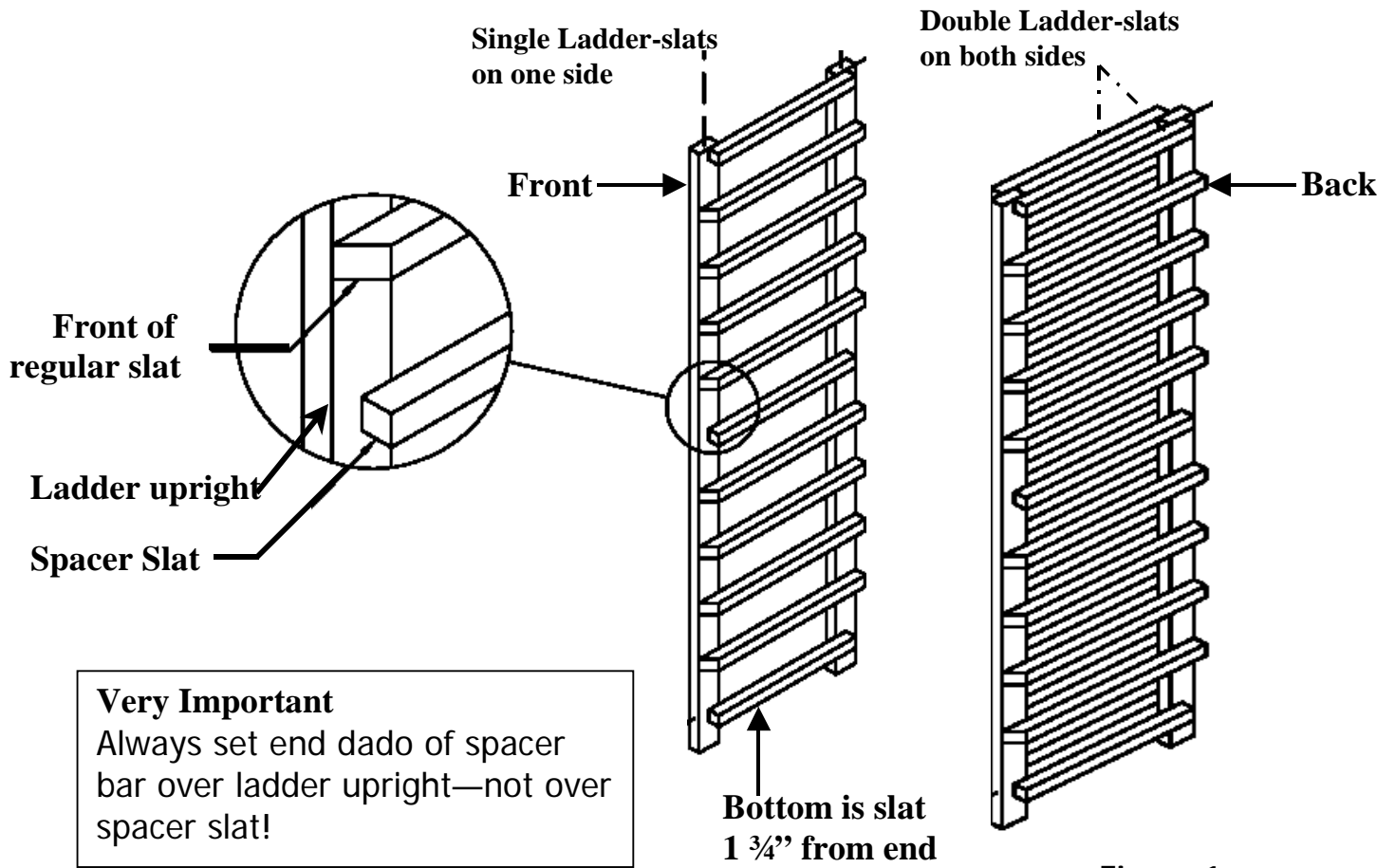

Figure 1

5 Column Spacer Bar

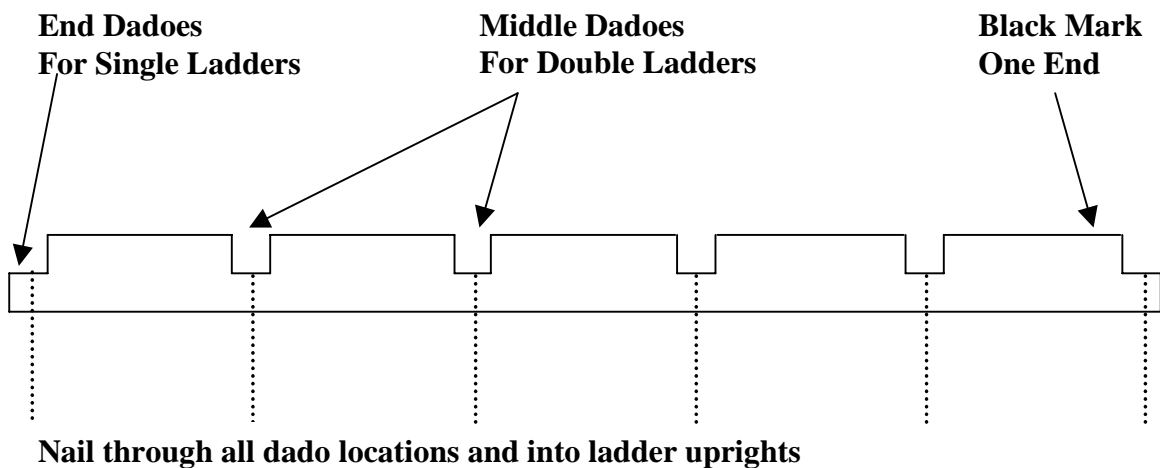
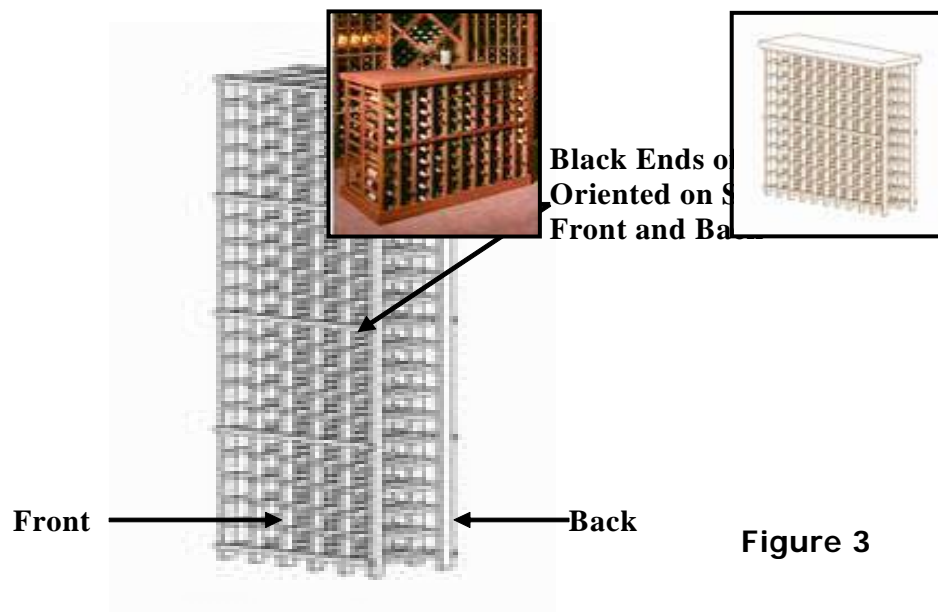

Figure 2

- A. Locate and unwrap the ladders and spacer bars for the first rack you intend to build, keeping like parts together. Stand the ladders upright against the wall and identify the single left and single right ladders. Set them aside for now.
- B. Take one of the **double** ladders and a spacer bar, stand the ladder upright (top to ceiling) with the front edge facing you.
- C. With nail gun in hand, take the spacer bar and set any one of the middle dadoes in the spacer bar over the front of the ladder upright and aligned vertically with a spacer slat, (starting with a spacer slat location from waist to shoulder height works best). Align the spacer bar vertically with the spacer slat behind it, tapping lightly with a soft faced hammer if necessary to fit it up, and nail through the spacer bar into the ladder upright.
- D. Get another double ladder and set it in the next dado on the spacer bar. Fit, align and shoot with a nail.
- E. Repeat step **D** until all **double** ladders are attached to the dadoes on the spacer bars.
- F. Locate the **single** ladders set aside and set them into the two remaining open dado locations. Insure that left and right are correctly oriented with slats facing inward and ladders and tops and bottoms matching those previously installed. Set the end dado against the front upright ladder at spacer slat location and nail through the dado and into the upright. Please see important note in **figure 1**.
- G. Once all dadoes have been filled with ladders you may attach the remaining spacer bars to the front of the rack at all spacer bar locations. Insure that the **spacer bar ends marked in black** are all installed on the same end of the rack. Work from the center out towards the top and bottom. Again the spacer bars may require a gentle tap to fit. See **figure 3** below.
- H. With the back of the rack facing you, attach remaining spacer bars at corresponding locations in the same manner as done in steps **C** through **G**.
- I. Place the rack against the wall in its approximate location.



## 2.2 Table Height Racks

Table height racks are assembled in exactly the same manner as a full height ladder rack. They are simply shorter than floor to ceiling ladders. Follow steps **A** through **I** in Section 2.1 to assemble your rack. The table's top and nosing will be installed after the rack is in its approximate location. This will be covered in Section 3.



### ***2.3 Display Racks***

Display racks are simply shorter ladder racks and have a bottle display angle on the top. They are assembled the same as individual ladder racks. Follow steps **A** through **I** in Section 2.1 to assemble.

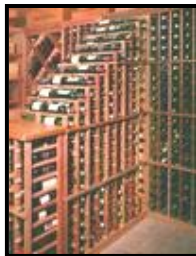

### ***2.4 Cascade Racks***

Cascade racks are assembled much the same as an individual ladder rack. You should note that the ladders are of staggered heights and vary by one bottle row height (3 ¾" for most racks). Please refer to Section 2.1 for ladder assembly basics, prior to proceeding with assembly.

- A. Find the two **single** sided ladders (the longest and shortest) and set them aside for now.
- B. Arrange the **double** ladders, in order from longest to shortest. Note that the tops of these ladders have slats on only one side. **The side with the extra slat should always be oriented toward its taller neighbor.** In this way a bottle can be supported on the top of each column. See **figure 4** for clarification.

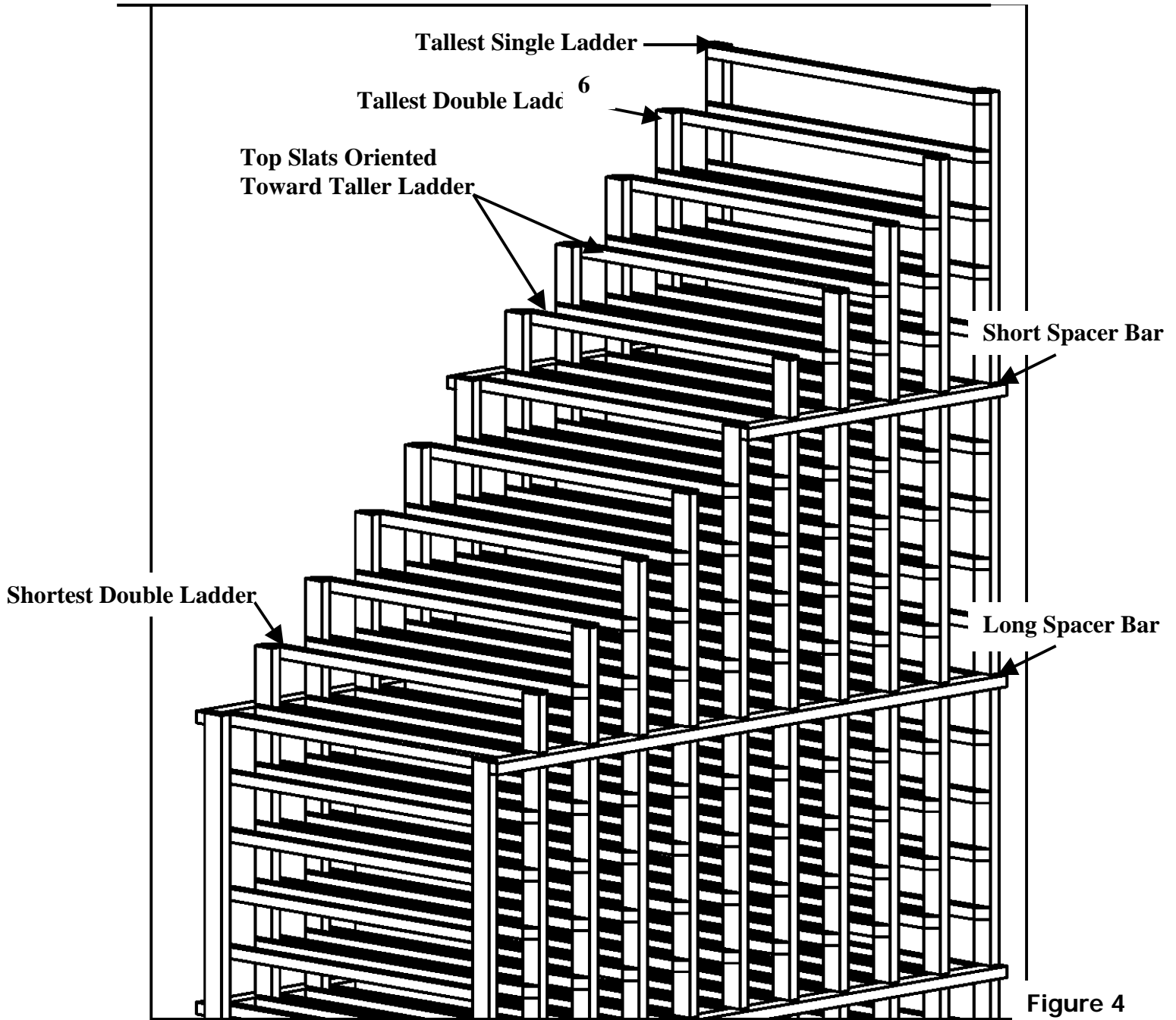
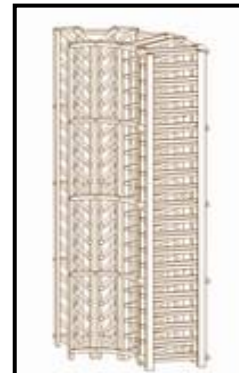
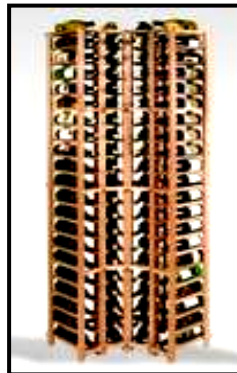

Figure 4

- C. You will notice the spacer bars are not all the same length, locate one of the long spacer bars, noting the black mark on one end.

- D. Now stand the shortest *double* ladder upright and attach the long spacer bar at the highest spacer slat location. See **figure 4** on page 6 for clarification. Use the second dado in, leaving the end location open for the short single ladder. The extra slat at the top should be facing the longer end of the spacer bar.
- E. Nail through the spacer bar and into the upright.
- F. Locate the next taller double ladder and orient it with the top slat facing in the same direction as the first double ladder. Set it into the next available full dado in the spacer bar and nail as before.
- G. Repeat Step F until all double ladders are attached to the spacer bar.
- H. Take the short *single* ladder and face it with slats facing toward other ladders. Attach ladder upright to end dado with a nail. Insure dado is set over upright and not spacer slat. See **Figure 1** page 3.
- I. Attach remaining spacer bars at spacer slat locations on each side of rack. **Take care to orient the black marked ends of spacer bars as described in Section 2.1, Step G.**
- J. Your cascade rack is now complete and ready to be moved into its approximate location.

See Section 2.7 for True Curved Corners



## 2.5 Segmented Curved Corner Racks

Segmented curved corners are assembled differently than other ladder racks, as they are first built in single column segments and then are assembled into a curve. Note that all the ladders are singles (slats on one side), with half being left hand and half right hand. Lefts will have the slats on the right hand side of the ladder when the angled slats are facing forward and the rights will have slats facing left. You should also note that there are four different types of spacer bars, they are shown on the following page.



**A: Back Spacer Bar**



**B: Column Spreader Bar**



**C: Front End Column Spacer Bar**



**D: Front Inner Column Spacer Bar**

**A:** Used to attach the backs of single ladders to create columns.

**B:** Used to connect the back of completed columns to create a corner.

**C:** Has a bevel on one side and is used to attach the fronts of ladders on the two outside columns.

**D:** Has bevels cut on both sides and is used to attach the fronts of ladders on the two inside columns.

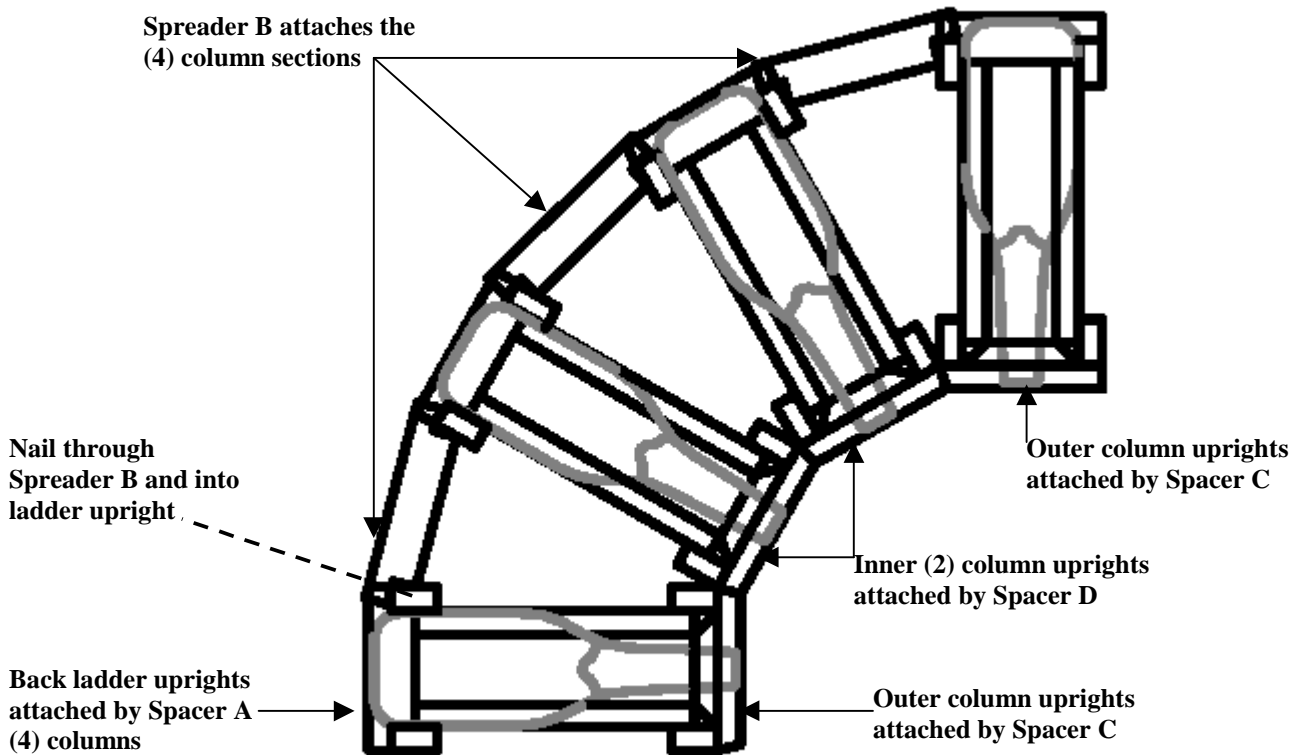
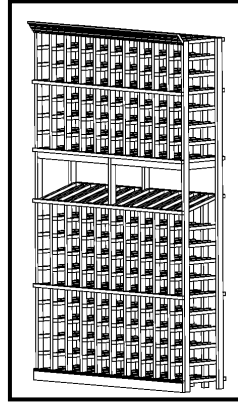

**Figure 5**

Please refer to Section 2.1 for ladder assembly basics, prior to proceeding with assembly.

- A.** To begin assembly of your segmented curve, get a left hand and a right hand ladder along with a back spacer bar (**A**). Set the ladders with the back facing you and the slats on each ladder facing one another.
- B.** Set the end dado on spacer bar (**A**) over one of the uprights at any spacer slat location, align and attach using a 1-1/2" brad.
- C.** Add back spacer bars at remaining spacer slat locations on **back** of column.
- D.** Repeat steps **A** through **C** for the remaining pairs of single ladders.
- E.** Now take *two* of the partially completed columns and using all of spacer bars (**D**), align and attach them to the front of both columns at all spacer slat locations. These are your inner columns.
- F.** Take the two remaining partially completed columns and using spacer bar (**C**), align and attach them to the front of both columns at all spacer slat locations. These are your outer columns. **Be sure that the beveled ends are all facing to the right on one column and to the left on the other column.**
- G.** Now place the two center columns side by side, with spacer bars (**D**) touching, and slide the backs apart approximately 6" until the bevels on the front spacer bars are close to flush.
- H.** Take a column spreader bar (**B**) and set it between the back uprights of the two columns at middle rack height. You may need to adjust the racks slightly for a good fit.
- I.** Nail through the spreader bar (**B**) and into the upright on each side (see **figure 5** previous page), keeping the spreader level.
- J.** Attach spreaders at two more locations as noted in **figure 5**, one near top and one near bottom of the assembly.
- K.** Now move the two outside columns to each side of the middle two, putting the sides with beveled spacer bars to the inside and against the other bevels. Spread the backs apart approximately 6" as before. Attach spreader bars (**B**) to each side being careful to line them up with the ones already attached. See **figure 5**.
- L.** To complete the assembly the front uprights need to be nailed to each other with 1-1/4" brads, at top middle and bottom. It may be necessary to clamp the uprights to get a good fit while nailing.
- M.** Your segmented corner is now ready to be moved into its approximate location.

## 2.6 High Reveal



Your High Reveal rack is a two part ladder assembly with normal rack storage on top and a display rack below for showing off your best bottles. Note that **figures 6** and **7** show a ten column High Reveal Rack with crown and base molding in place of a spacer bar. It may differ from your rack in size and style depending on your design.

- A.** To begin assembly, locate your full length ladders (2 or 3 depending on the number of columns you have) and upper double ladders (no display angle on top). Using **figure 6** below as a guide, assemble the top half as you would any other ladder assembly following steps **A-H** on page 4.
- B.** Attach all upper ladders, ending with the 3<sup>rd</sup> spacer bar from top in **figure 6**. Now add the beam support boxes (1 or 2 depending on number of columns) inside the full length ladder uprights. Set them flush with the ladder uprights and against the bottoms of the upper ladders. Nail them in place through each upright.

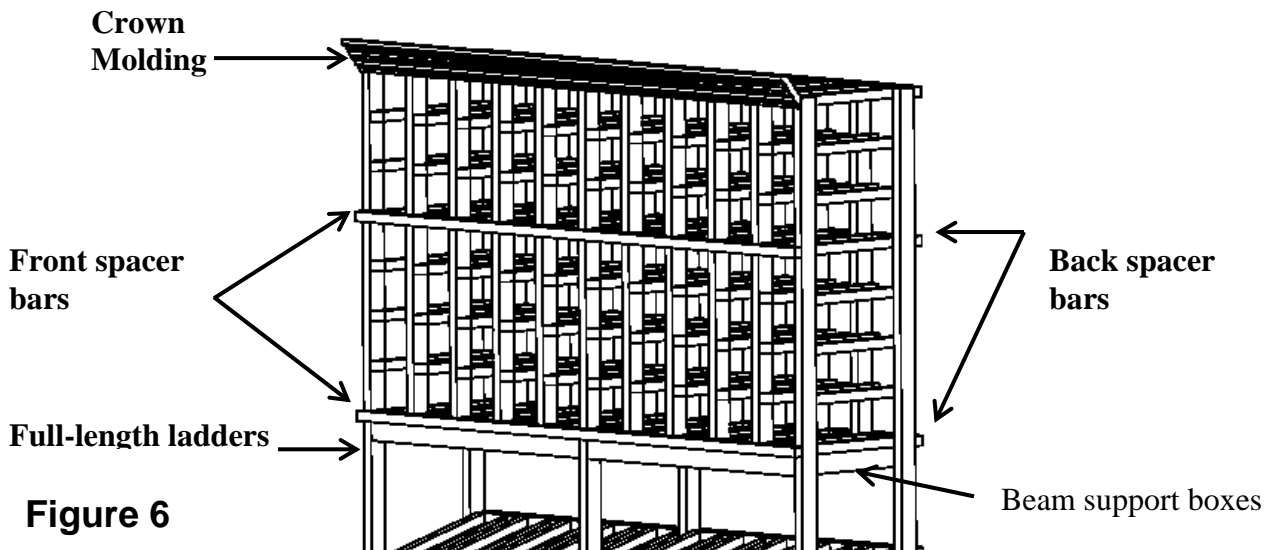

**Figure 6**

- C.** Locate a lower display ladder (display angle on top) and set it inside the left hand full length ladder with the high end of the ladder to the back. Insure that the ladder bottoms are even.

- D.** Set a spacer bar at the front spacer bar location (low end of the angled slat) over the full length ladders and the lower display ladder, see **figure 11**. Now carefully add all lower display ladders until all dadoes have been filled.

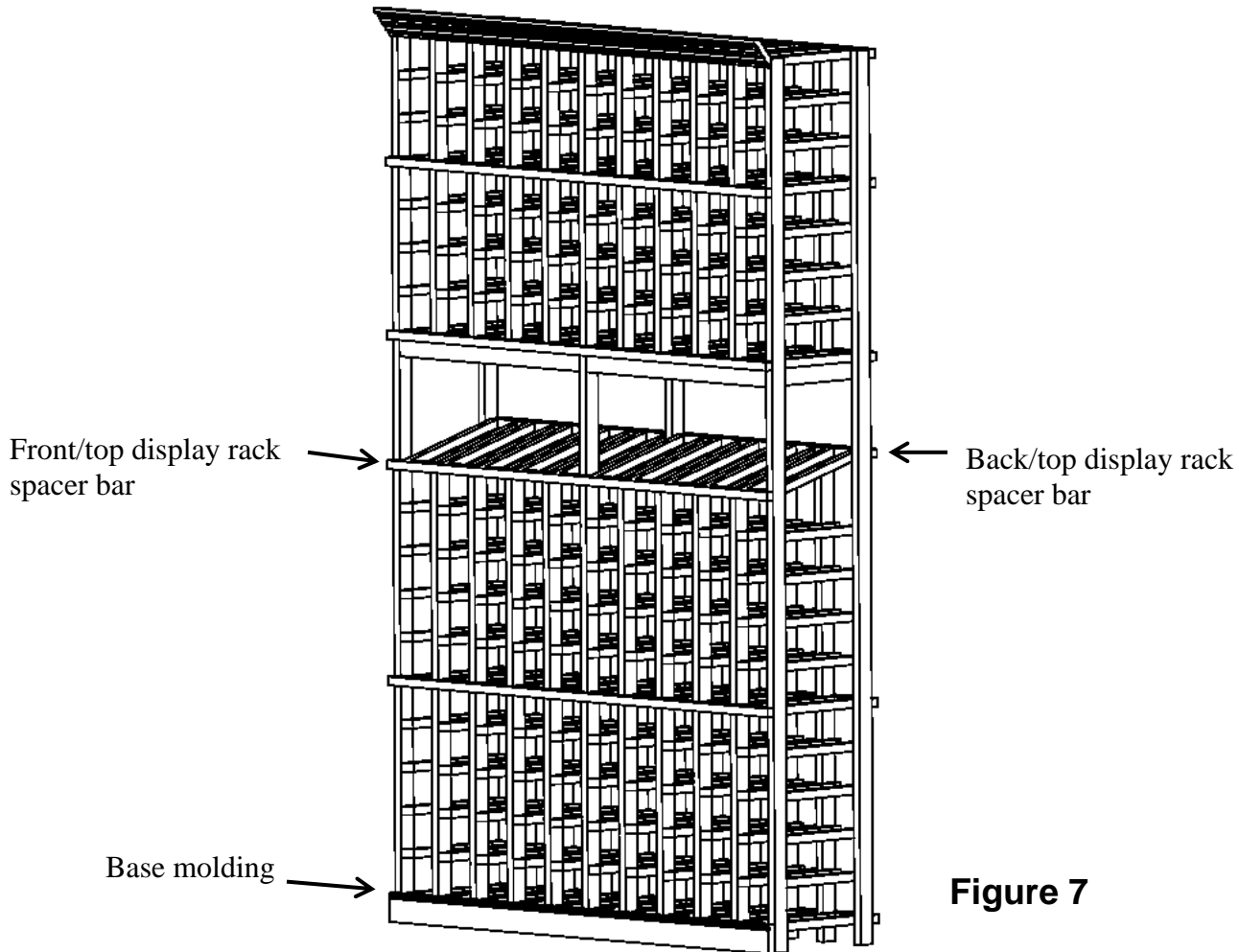

**Figure 7**

- E.** Insure that all ladders are at the same height and the spacer bar is level end to end. Nail through the spacer bar and into all ladders checking height and level as you go along.
- F.** Add additional spacer bars and base molding to the front as necessary, aligning and nailing as before.
- G.** Attach remaining spacer bars in the back, starting with the location at the high point of the lower display ladder and adding spacer bars as necessary to the bottom of the rack. Align and nail in place as on the front.
- H.** Your high reveal rack is now complete and ready to be moved to its approximate location.

## 2.7 Diamond Bins

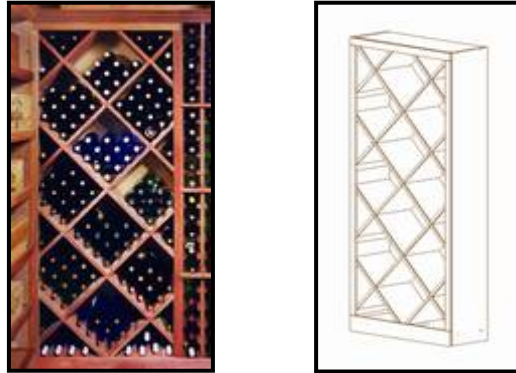

Prior to assembly of your custom diamond bin, locate the individual custom drawings of your diamond bin. These drawings will be needed to assemble the inside panels of your bin. Your custom diamond bin has been shipped to you flat, in panel sections. Familiarize yourself with the following illustration, taking note that the four outside panels are labeled as top, bottom, left and right.

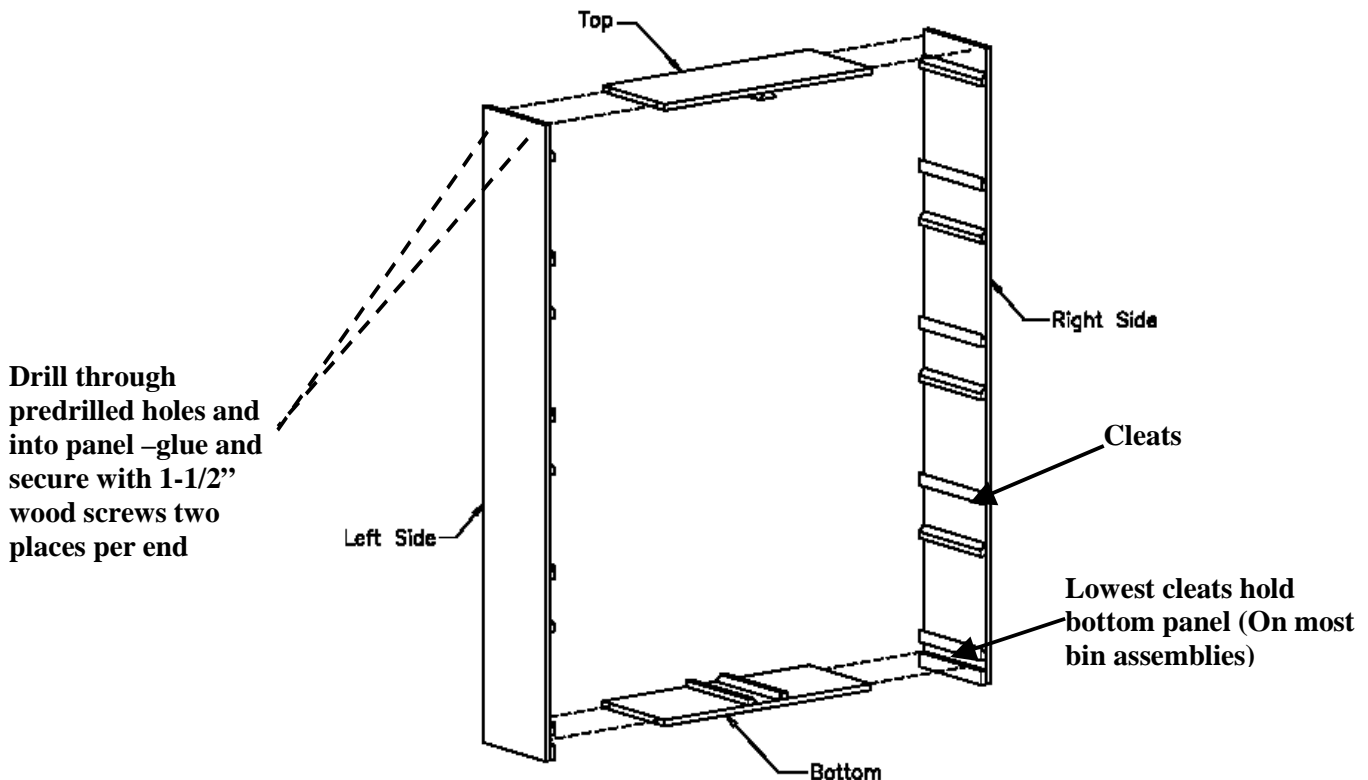
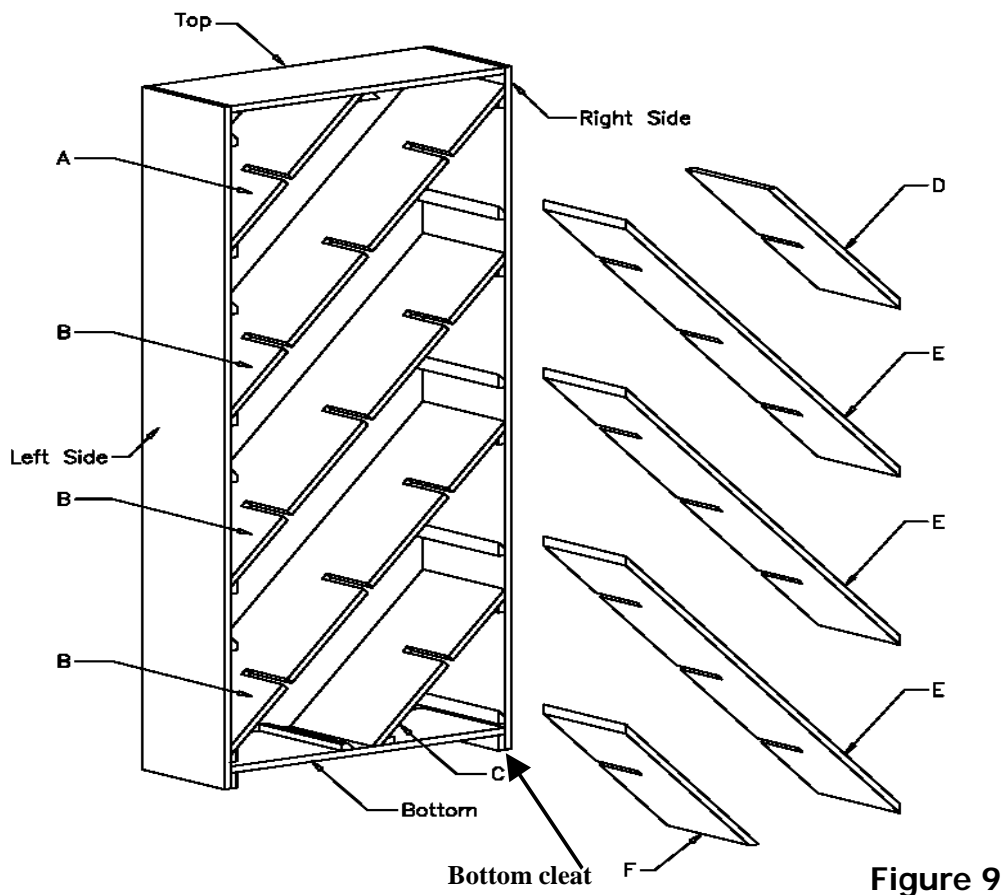
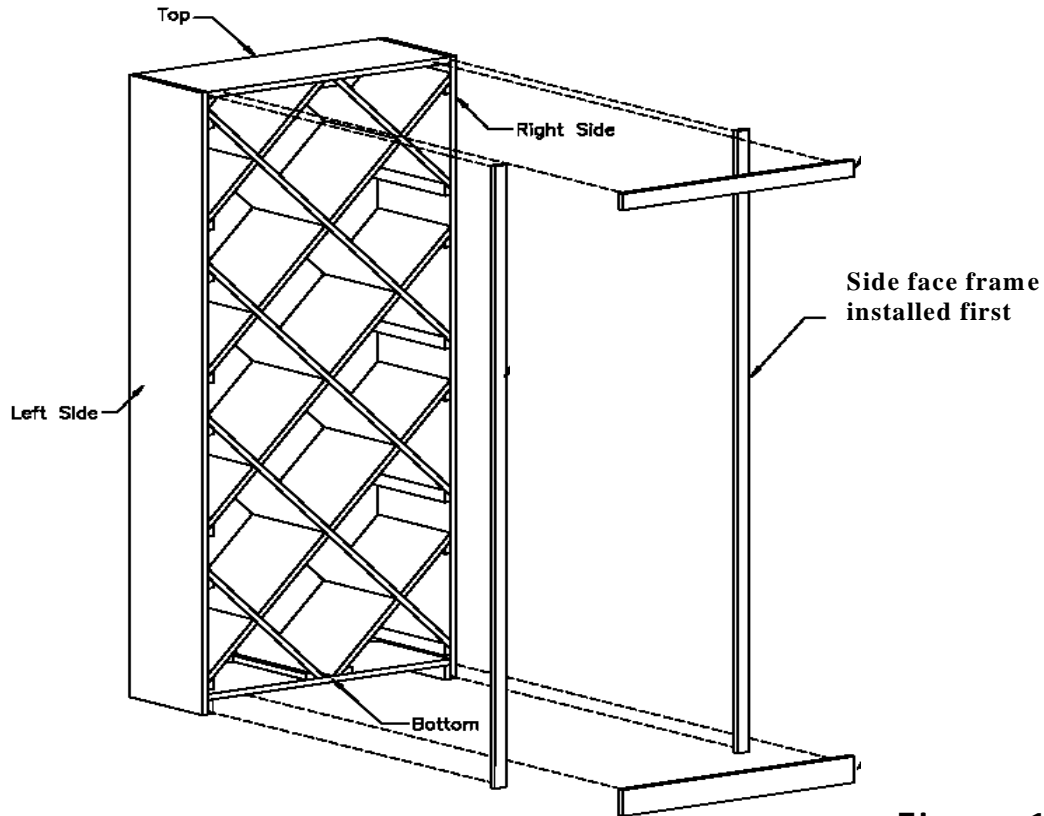

Figure 8

- A. To begin assembly of your diamond bin, locate the two side panels and top and bottom. In most cases side panels will have cleats at the very bottom. Note that the panels are finished (edge-banded) on one edge only. Orient the pieces on the floor as shown in **figure 8**, being sure that the finished edges are all facing up.
- B. With drill and pilot bit at the ready set the left side panel and top panel against each other and carefully align the edges. Drill a pilot hole through the pre-drilled holes on the left side and into the top. See **figure 8**.
- C. Apply some wood glue to the joint and screw together using two 1 1/2" wood screws. Attach the right side to the top in the same manner.
- D. Set the bottom panel between the side panels, sitting it on top of the bottom cleats on the side panels, as shown in **figure 9**. Align, drill, glue and screw in two places on each side.
- E. **Figure 9** below, shows a typical diamond bin and is for reference only. Your custom bin will differ in the location and number of panels. Locate all panels listed on your custom drawing, these panels will be labeled on the back edge with letters to match those on your drawing.
- F. Slide the panels into the box as shown on your **custom drawing**. Use the cleats as a guide. Always slide first set of panels in with finished edge and slots facing you.



G. Once all interior panels have been installed, apply face frame (if in your design). Locate the four face frame pieces and apply as shown in **figure 10**.



**Figure 10**

H. Starting with one side, apply wood glue and align the edges with box frame top and bottom, then shoot with finish nails. Finish in the same manner with the top and bottom and finally the opposite side.

I. Stand the diamond bin up and set it in its approximate position.

## 2.8 Curved Corner Racks

See Section 2.5 for Segmented Corners

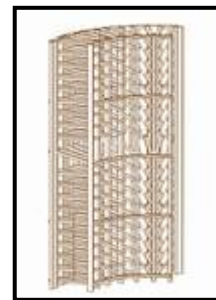

Your curved corner assembly consists of (5) pie shaped doubled ladders and (2) single ladders; one left and one right. See **figure 11.1**. You will also find (42) 5" long spacer bars, (3) curved front spacer bars, (1) curved crown and (1) curved base.

**Important Note**  
Spacer bars are attached  
to ladder uprights---Not  
to slats!

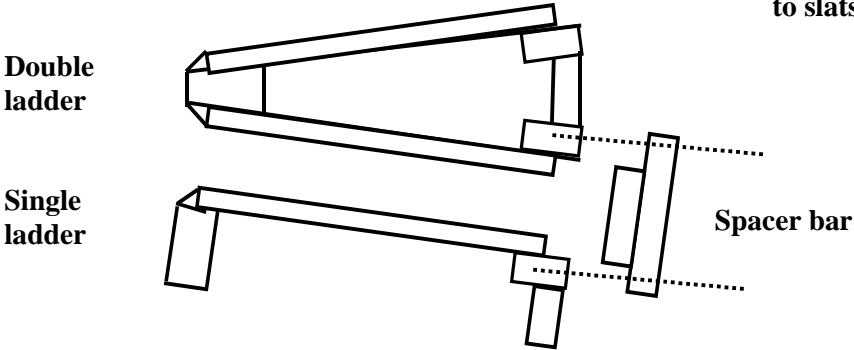

Figure 11.1

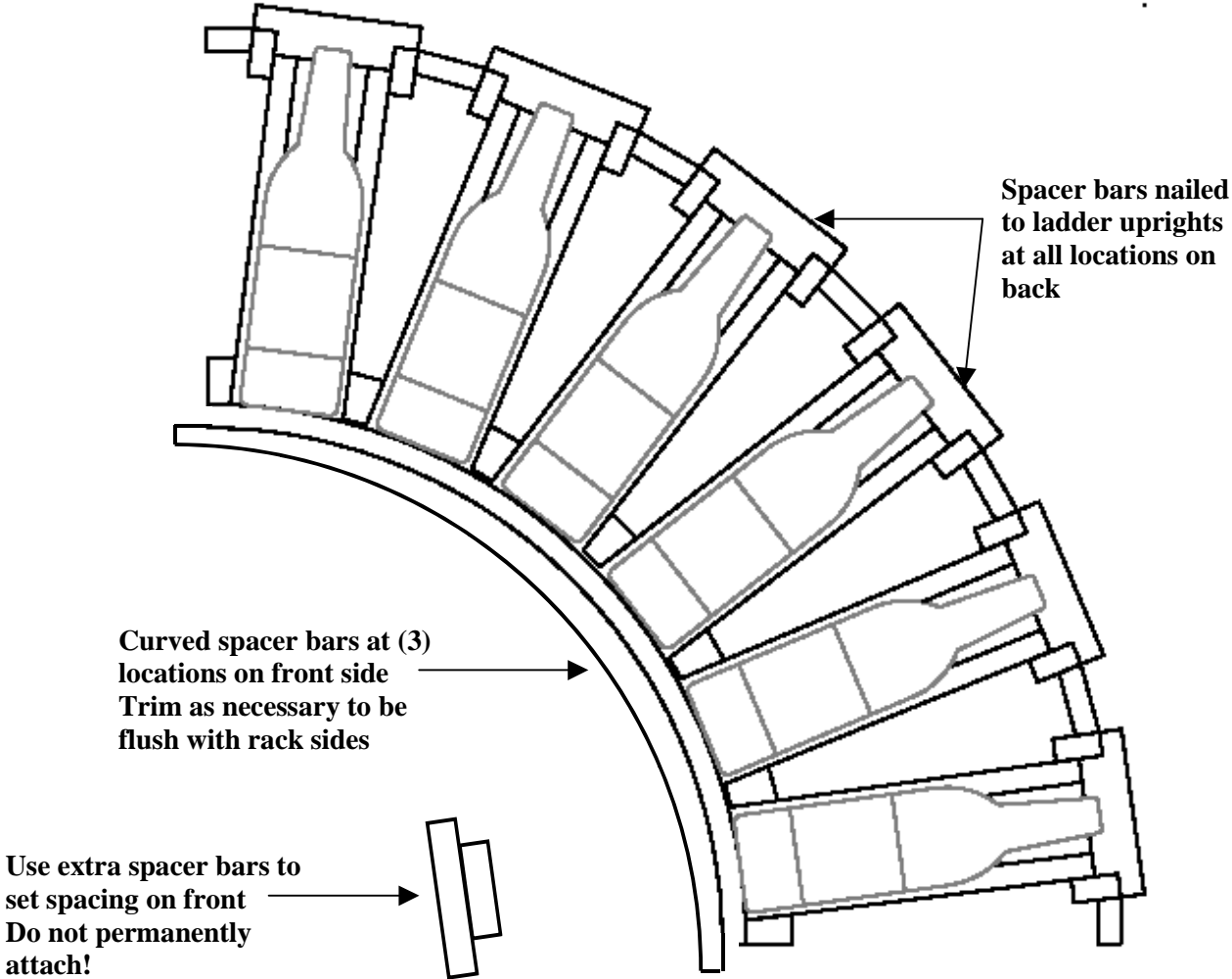

Figure 11.2

- A. Stand the right hand single ladder and a double ladder upright with the slats facing each other. Attach a 5" spacer bar by nailing through and into the ladder uprights with 1-1/2" galvanized finish nails as shown in **figure 11.1**
- B. Add spacer bars at remaining back spacer slat locations to complete each column.
- C. Continue by attaching the remaining double ladders and end with the left hand single ladder (slats facing inward). You will be left with (6) straight spacer bars, which will be used to set the spacing between columns in the front of the rack. See **figure 11.2**
- D. In front of rack set a straight spacer bar in each column in the rack front just above the location of the center curved spacer bar. Use a bar clamp to secure from end to end. Front spacer bars attach at all slat locations without angles.
- E. Hold a curved spacer bar in location using a screw clamp to draw it in to fit if necessary. Scribe the ends where they overhang the rack and cut as needed to sit flush with the sides. See **figure 11.2**
- F. Now secure the curved spacer bar to the upright using 1-1/2" galvanized finish nails. Add the other two curved spacer sections in the same manner.
- G. If you are using crown and base molding, now is a good time to scribe and cut it to length. Do not nail the molding on yet, but save it for the final finish work, when all molding will be applied.
- H. Move your curved corner assembly into its approximate position. It will attach to contiguous racking by nailing through outside uprights using 1-1/4" brads.

## 2.9 Rectangular Bins

The rectangular bin is a simple shelf assembly made for bulk storage. It is assembled in fashion similar to other ladder assemblies. Each adjustable shelf sits on shelf pins that fit into the dadoes on the bottom of each shelf.

- A. To begin assembly of your solid rectangular bin, locate the two side panels, top and bottom. Note that the panels are finished (edge-banded) on one edge only. Arrange the pieces on the floor as shown in **Figure 12**, be sure that the finished edges are all facing up.
- B. With drill and pilot bit at the ready, set the left side panel and top panel against each other and carefully align the edges. Drill a pilot hole through the pre-drilled holes on the left side and into the top. See **Figure 12**.
- C. Apply some wood glue to the joint and screw together using two 1 1/2" wood screws. Attach the right side to the top in the same manner.
- D. Set the bottom panel between the side panels. Align, drill, glue and screw in

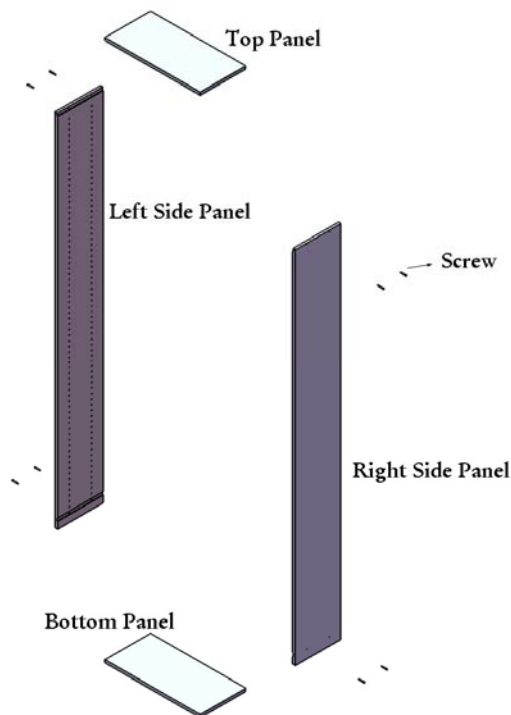

**Figure 12**

two places on each side.

- E. Using the same attachment procedure, attach the two nailers; one at the top and one at the bottom of the solid rectangular bin carcass.
- F. To complete your assembly, place shelf pins in each place you desire your shelf. Place each shelf on the shelf pins using the dadoes on the bottom of each shelf.

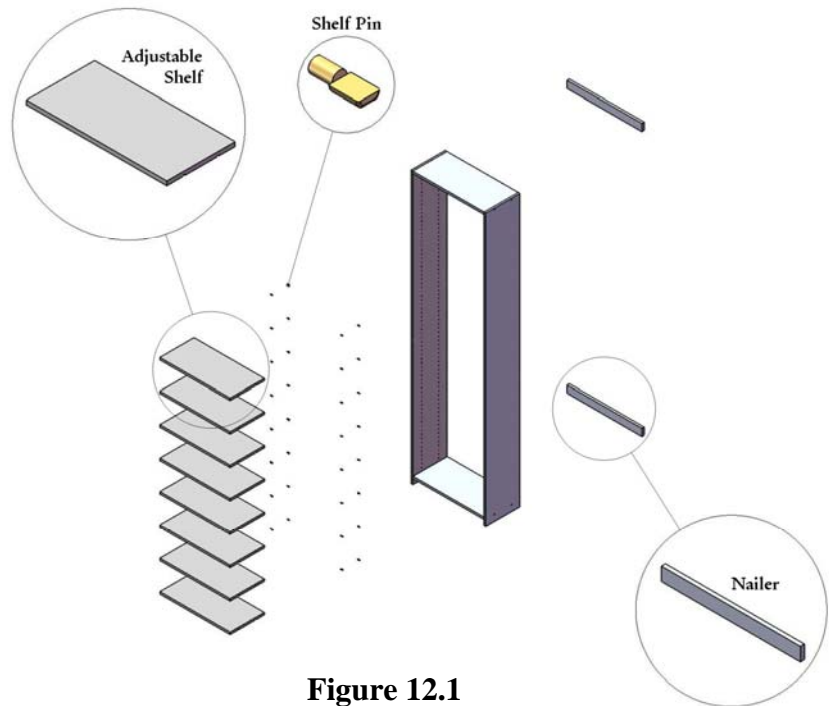

Figure 12.1

## 2.10 Vertical Displays



Your vertical display has been shipped to you in panel sections. You will have two side panels with a series of predrilled holes (for adjustable shelf pins), top and bottom panels, a back panel, biscuits (8), horizontal shelves and lengths of face frame. All panels are labeled on the back edge.

- A. Apply a small amount of glue to the slots in the inside face of one side panel and fit two of the biscuits into the slots. Apply some glue to the slots in one end of the top and align with the biscuits. Fit together and fasten with 1-1/2" galvanized finish nails.
- B. Using two more biscuits attach the bottom in the same manner.

- C. Attach the other side panel using the remaining biscuits, securing with finish nails.
- D. Attach the back panel to the rectangle using 1-1/2" finish nails.
- E. Using the shelf pins provided, set the shelves at their final locations.
- F. Apply face frame to the outside of the display case as shown in **figure 10** on page 14. Follow steps **F** through **H** in Section 2.7 (same as diamond bin) to install.
- G. Move your vertical display into its approximate location, as shown on the floor plan.

## 2.11

### ArchTops



Arch tops come in two distinct styles, a True Arch, which is built with two sections of true curved wood and a Soffit Arch, which has a top soffit section in the shape of an arch. Your arch top has been custom designed and built to fit into your floor plan.

#### 2.11.1 True Arch



Your true arch comes fully assembled and needs only to be set in place and attached to adjacent cabinets or racks.

#### 2.11.2 Soffit Arch



Your soffit arch consists of four sections, (1) bottom panel, (2) side panels, and (1) top soffit arch. Refer to **Figure 13** below

- A.** To begin assembly, locate the two side pieces, distinguished by the row of slats on one side of the panel. The sides are also  $\frac{3}{4}$ " wider than the bottom. Note that all panels are finished (edge-banded) on one edge only. **Be sure to assemble all pieces with the finished edges facing the same direction**, this will be the front of your soffit arch.
- B.** On a flat table or floor, orient the panels as shown in the diagram on the following page. Apply some wood glue to the joints and align all panel edges carefully. Note that the bottom panel is designed to overhang in the front by  $\frac{3}{4}$ ".

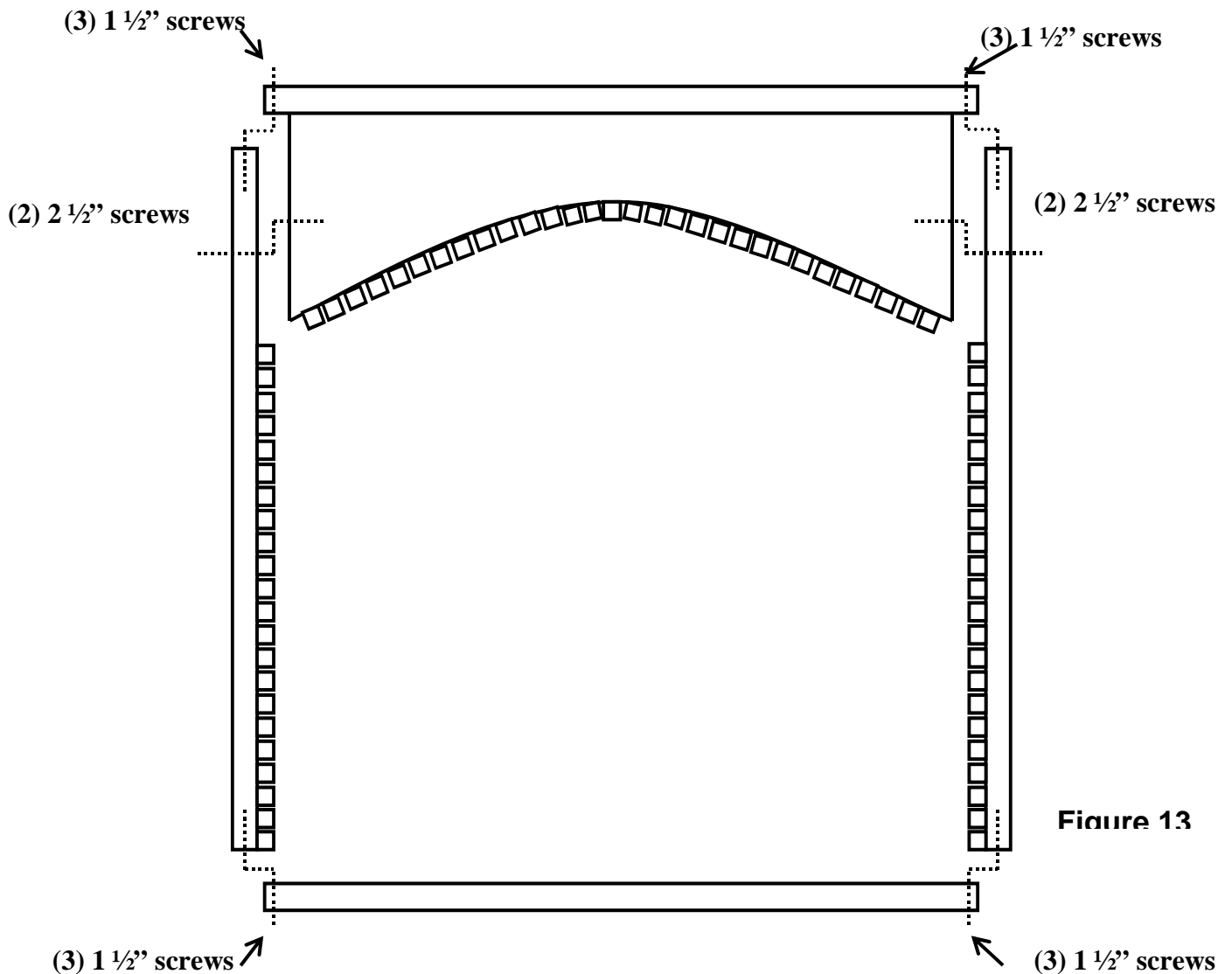
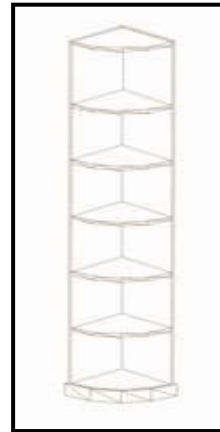

**Figure 13**

- C.** Using the pilot drill bit provided to you, drill through the six existing holes in the soffit arch top and into the panel sides. Take care to keep the edges aligned.
- D.** Attach the top to the sides using (6) 1 1/2" long screws.
- E.** Align the bottom panel in a similar fashion, lining up *back* edges only, as the front will overhang  $\frac{3}{4}$ ". Pilot drill and screw in (6) places as on the top.

- F.** Check the arch for square, measuring diagonally corner to corner, adjusting with a soft-faced hammer if necessary to achieve an equal measurement on both diagonals.
- G.** Drill through the two existing holes on each side of the arch and into the top. Attach using the (4) 2 ½" long screws.
- H.** Your soffit arch is now complete and ready to be moved to its final location atop a table or rack.

## ***2.12 Quarter Round Shelves***



Your custom quarter round shelf has been shipped in panel sections. It consists of two long side panels, a number of quarter round shelves and curved finish molding.

- A.** To begin assembly, place panel A against a wall with the side that has three slots cut in it facing toward you. See **figures 14.1** and **14.2**.
- B.** Locate the three oval shaped biscuits, apply a small amount of wood glue in the slots, and slide the biscuits into the slots in panel A. See **figure 14.2**.

Figure 14.1

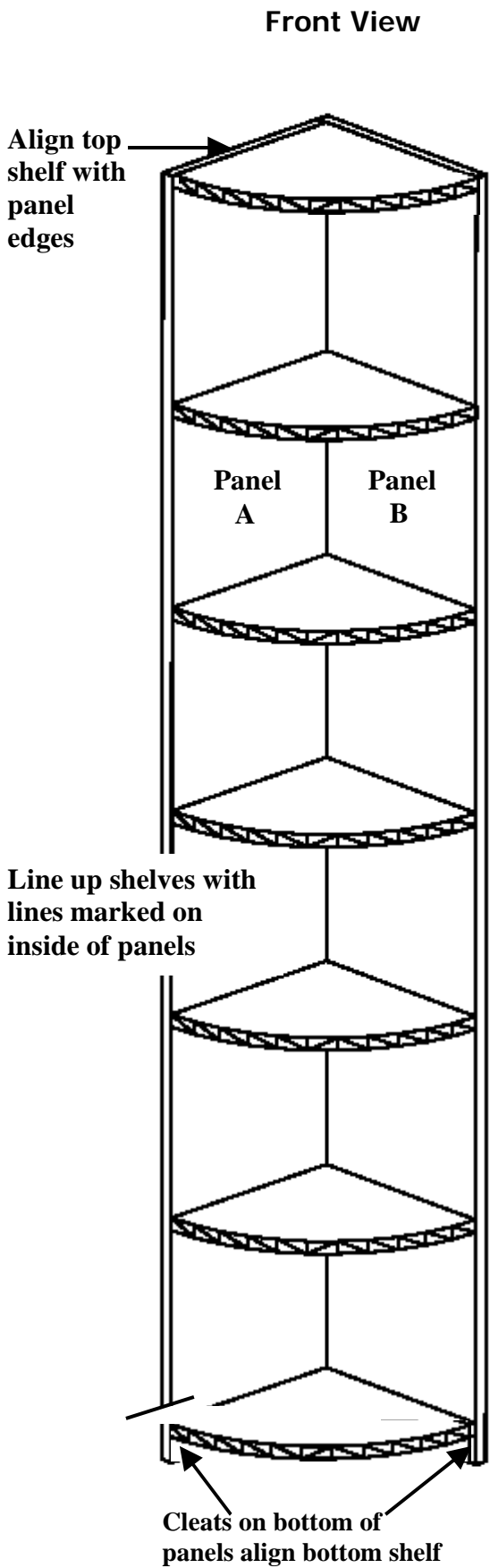

Figure 14.2

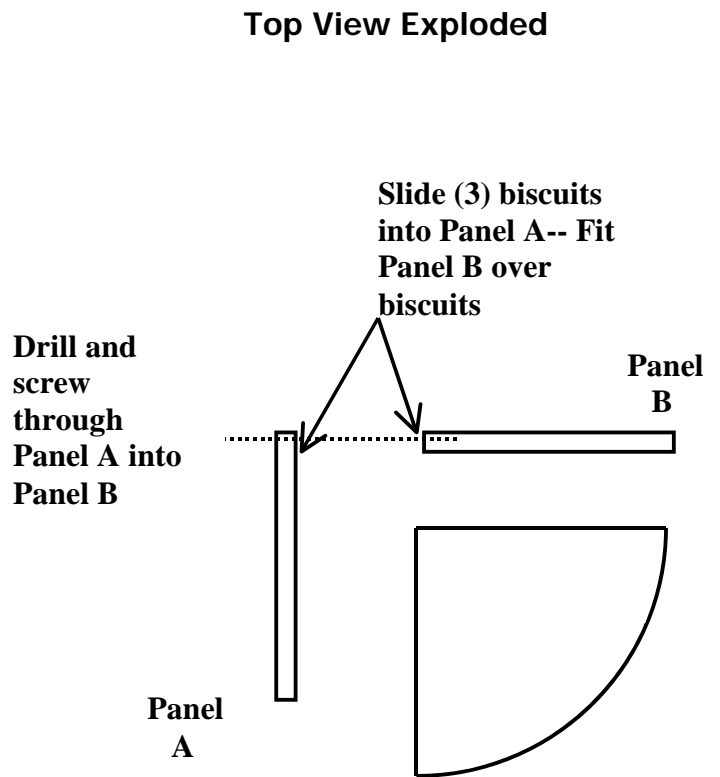
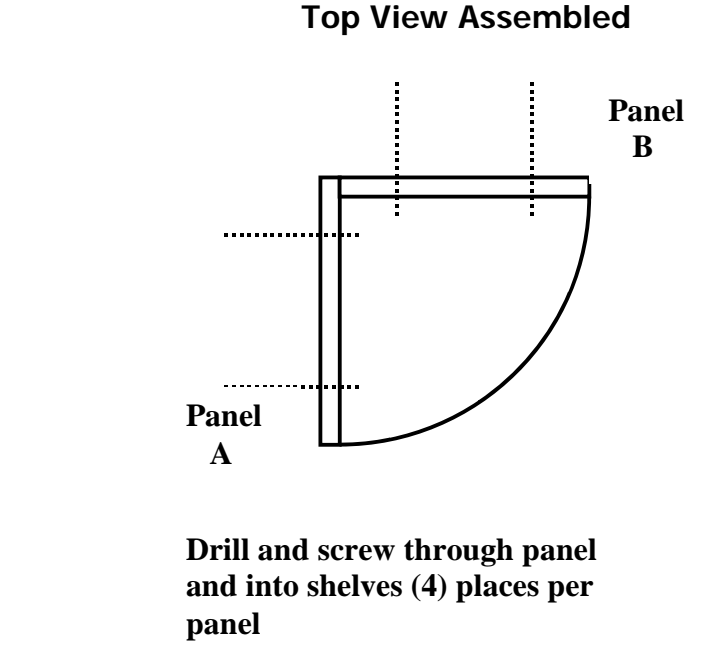

Figure 14.3



- A. With the finished edge of panel B facing out, apply a small amount of glue to the three slots on the back (unfinished) edge. Line up the slots with the biscuits in panel A and fit the panels together.
- B. Using a pilot drill, drill through the predrilled holes in panel A and into panel B. Attach the panels using 1-1/2" wood screws.
- C. Set the first shelf on top of the cleats at the bottom of the panels. Drill two holes through the back of panel A into the shelf and secure with 1-1/2" wood screws. Repeat this process on the back of panel B. See **figure 14.1, 14.2, 14.3.**
- D. Align the top shelf with the top edge of the panels, drill and screw as in step E.
- E. To attach the remaining shelves, align them at the locations marked on the insides of the panels, drill and attach with screws. See **figure 14.1.**
- F. You may now move your quarter round display into its approximate location on the floor plan. Set aside the curved finish moldings to apply later.

### ***2.13 Wood Case with Pull Out Shelves***



Your wood case with pullout shelves is a basic ladder assembly made to hold wine cases. It is assembled in similar fashion to other ladder assemblies. It consists of two ladders with extension shelf slides attached, spacer bars, and number of shelves with predrilled holes to attach the corresponding shelf hardware. See **figure 15** on the following page.

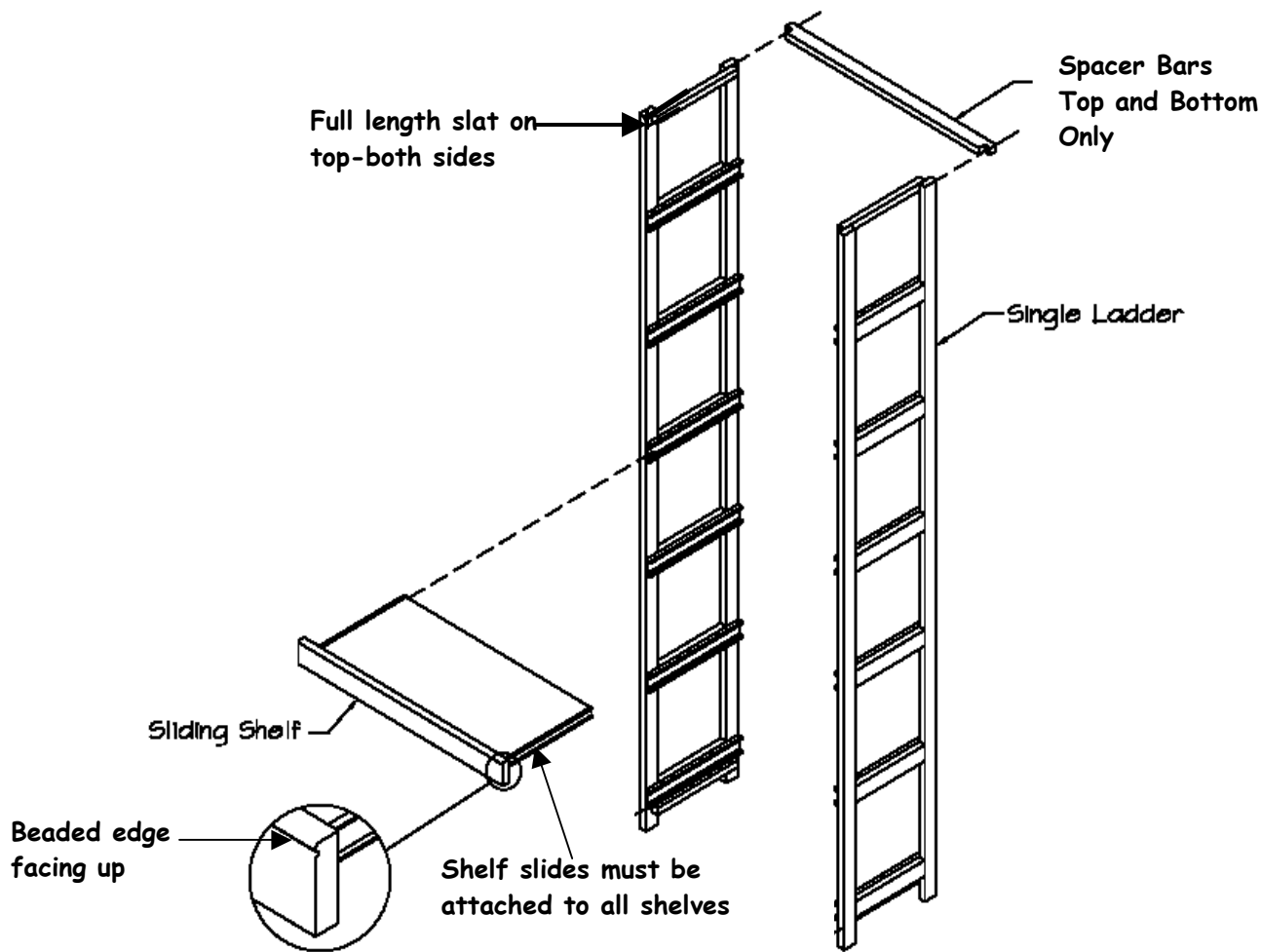
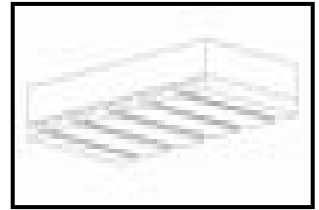

FIGURE 4E

- A.** Stand the ladder racks upright with the shelf slides facing inward. The ladder has a full slat at the very top of the upright and is flush to the front of ladder. Attach the spacer bars at two locations, top and bottom on the back only. Crown and base molding will hold fronts of ladders in position.
- B.** Set the spacer bar dadoes over the ladder uprights and shoot with 1-1/2" galvanized finish nails. The rack will be a bit unstable until the shelves are installed.
- C.** Attach the loose slides to both sides of all shelves, using a hand screwdriver to screw through the predrilled holes in the shelf sides. **Using a screw gun or over tightening the screws may strip the holes.**
- D.** Place the assembled shelves into the receiving extensions in the rack, sliding back as far as possible and then pushing the front firmly toward the floor. It will then lock into place.
- E.** Move the rack into its approximate location according to the floor plan. (Note: Rack will be wobbly until fastened to adjacent racks and secured with base and crown.)

## 2.14 Stemware Racks



Your stemware racks come to you completely assembled. They need to be located per the floor plan and attached to adjacent racks above and to the sides.

## 3. Finish Work



### 3.1 Final Assembly

Now that all of your racks have been completed and are in their locations according to the floor plan, be sure that they are plumb and level. It may be necessary to shim, as site conditions may vary. Once all the racks are plumb and level, **it is essential that they be secured to each other as well as to the walls. A rack fully loaded with bottles may weigh up to 1000 pounds and must be securely fastened to other racks and several wall stud locations.**

- A. Using a pilot drill, drill through the ladder uprights or panels and into the adjacent rack in several locations per rack. Fasten together with 1 1/4" wood screws or you may choose to fasten together with 1-1/4" brads.
- B. Locate your wall studs and secure all racks by drilling through the top back spacer bar and into available stud locations. Fasten to walls using 3" wood screws.

### ***3.2 Corners***

You have been provided with mahogany strips that may be used to fill in and finish any corners where racks meet.

- a) Begin by ripping two strips lengthwise to fit, approximately 1 ½” wide. Cut both to length to fill the vertical gap.
- b) Glue and nail together with brads to form a 90° “L” shaped piece.
- c) Stand the 90° “L” upright and fit into the gap. Nail through adjacent spacer bars and case work and into fillers.

### ***3.3 Crown and Base Molding***

Locate the base and crown molding provided to you with your racking. If you have purchased any curved corners, there will be separate curved moldings for these. The standard crown provided is 2 ½” wide and should be attached to the face of the racking with galvanized finish nails.

Locate any curved moldings for curved corners and attach them first with galvanized finish nails. Working out from any curved corners, apply straight sections of crown and base molding. Any straight corners will need to be cut and mitered to fit.

The crown should ideally land at the bottom of the top slat and may or may not go all the way to the ceiling, depending on your design. If your design calls for molding to reach the ceiling, start there and attach it wherever it lands on the racking. The base molding provided is designed to run along the floor fastening to the racking. The base should run up onto the top of the bottom slat. If the racks were shimmed to meet site conditions, the base may need to be raised slightly off the floor or left below the top of the bottom slat. Excessive shimming may require a wider base and scribe work.

### ***3.4 Finishing Touches***

To add the final finishing touches to your wine racks first fill all nail holes with matching colored wood putty. Using a soft cloth add some of the Danish oil (if provided) to cover any areas that have been sanded. It is now time to fill your wine racks with your wine collection, reserving your favorite bottle to open, breathe and enjoy!